



IJRASET

International Journal For Research in
Applied Science and Engineering Technology



INTERNATIONAL JOURNAL FOR RESEARCH

IN APPLIED SCIENCE & ENGINEERING TECHNOLOGY

Volume: 11 **Issue:** IV **Month of publication:** April 2023

DOI: <https://doi.org/10.22214/ijraset.2023.50178>

www.ijraset.com

Call:  08813907089

E-mail ID: ijraset@gmail.com

Investigation on Buckling Behaviour of RC Rectangular Long Column Confined with Aluminium Mesh

Mr. Arun C.K¹, Prof. Divya K.K²

¹M-Tech Scholar, ²Associate Professor & Head, Department of Civil Engineering, Vedavyasa Institute of Technology, Karadparambu, Malappuram, Kerala, India

Abstract: Confinement provided in the column enhances the strength characteristics, load bearing capacity, ductile properties, energy absorption and overall durability of the structure. This paper analytically investigate the buckling behaviour of long column confined with aluminium mesh. Here the confinement material taken as alloy of aluminium specifically Al-T6-6061. Less corrosion, high strength to weight ratio, material availability in the market make the Al-T6-6061 as a peculiar one suitable for the confinement of long column. Buckling load, ultimate load and deformation are investigated analytically using finite element software Ansys workbench 2021 R2. Aluminium mesh confinement enhances the load bearing capacity of the long column. Witnessed 14.1% increase of buckling load w.r.t conventional long column.

Keywords: Confinement, Buckling behaviour, Al-T6-6061, Strength to weight ratio, Ansys work bench 2021 R2

I. INTRODUCTION

RCC columns are the most important structural element in the building frame. Column transfers the entire load of the building including slab and beam to the foundation. Foundation transfer this load to earth. All massive compressive loads are supported by the column. So when the failure of column happens, the entire structural system will be collapsed. In order to improve the overall performance of the column, it is required to strengthen it by providing additional confining reinforcement. The performance of the confined column improves the strength, load bearing capacity, ductility and durability of the column. It is proved that spirals in the circular column performs well w.r.t confinement. But circular columns are used mainly to improve the aesthetics of the buildings and not widely used w.r.t rectangular column considering the ease of construction. Rectangular column with lateral ties are not effective as spirals in the circular column. Hence it is important provide additional confinement to the rectangular column. Transverse reinforcement in the column act as the shear reinforcement and provide confinement for compressed concrete. It also help to prevent premature buckling of compressed longitudinal bars and resist shear forces and help to avoid shear failure. Columns are classified into short column and long column (slender column) based on the slenderness ratio. If the slenderness ratio more than 12, it is said to be long column. Long columns are more vulnerable to buckle. There are various means of confinement material which are glass fibre sheet, fibre reinforced polymer sheet, carbon fibre polymer sheet, Ferro cement wall, welded textiles, etc...Amongst these materials, alloy of Aluminium specifically Al-T6-6061 is being chosen as confining material because of its advantages, including low weight, high strength and weldability, good corrosion resistance, free maintenance, no ferromagnetic properties, flexible manufacturing procedures and availability in the market. Non-linear model analysis was conducted which was used for the analysis of reinforced concrete structures. It was noticed that only a non-linear stress-strain model for the confined concrete in compression could predict the ultimate load and corresponding deflection with great precision.

II. OBJECTIVE OF THE RESEARCH

- 1) To model the reinforced concrete rectangular long column confined with aluminium mesh (Al-T6-6061)
- 2) To compare the buckling behaviour of reinforced concrete rectangular long column confined by aluminium mesh with conventional reinforced concrete rectangular long column.

III. METHODOLOGY

In this research literature study has been carried out for collecting relevant information on confinement concept and properties of aluminium and its alloys. Objectives are defined such that the research will be helpful for the future studies on confinement concept. Column designing has carried out using IS-456 2000, SP 16.

Software analysis has been completed in Ansys workbench 2021 R2. Studied the buckling behaviour of AI confined reinforced concrete long column w.r.t conventional long column. Evaluation of results and discussion of result has been carried out after the analysis. By completing the discussion on result obtained, arrived at a conclusion on the entire work.

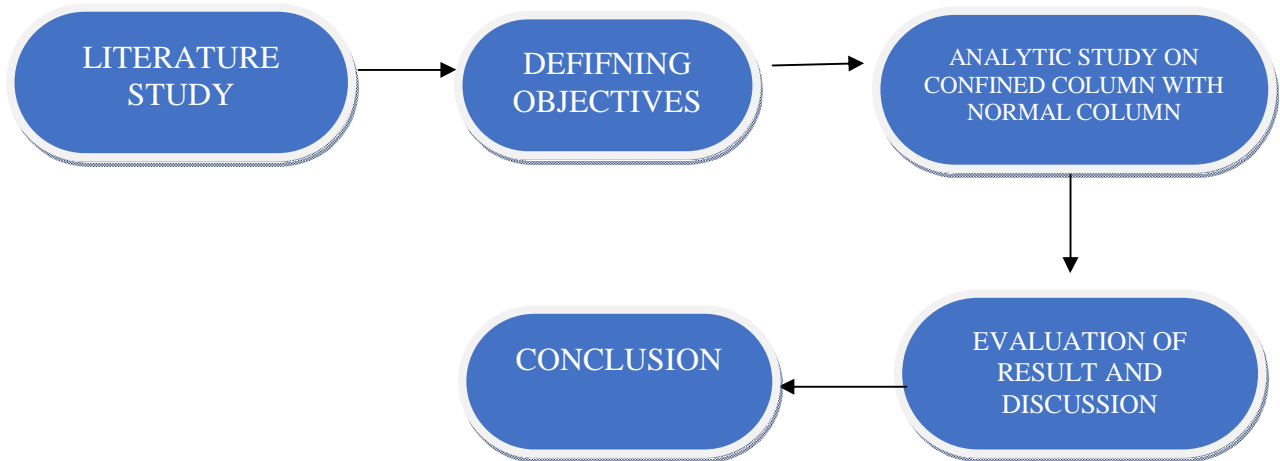

Figure 3.1. Methodology of work

IV. DESIGN OF LONG COLUMN

Long column has been designed according to IS456 200, SP 16. Size of the column is taken as 400X300 from IS456 200, SP16. Concrete mix is M30. Yield strength of steel is taken as 415 N/mm². Effective length for bending parallel to larger dimension (l_{ex}) is taken 6m. Effective length along shorter dimension (l_{ey}) is taken as 5m. Unsupported length of the column is 7m. Factored load acting on the column is 1500 KN. Factored moment in the direction larger dimension is 40 KNm at top and 22.5 KNm at bottom. Factored moment in the direction shorter dimension is 30 KNm at top and 20 KNm at bottom. Long column is bent in double curvature and provided with the cover of 50mm. Column is provided with 12 number of longitudinal bars of diameter 20mm. 8mm lateral ties have been provided with 300mm centre to centre throughout the height of the long column.

V. FINITE ELEMENT ANALYSIS

Since experimental research is very expensive and time consuming, a simulation software known Ansys workbench 2021 R2 is used to model analyse the long column. Nonlinear analysis is possible in this version of Ansys. The nonlinear finite element approach has been widely used for analysing reinforced concrete members past the last two decades. These kinds of simulation software generates large amount of valuable data. Normal stresses and shear stresses, displacements, crack distributions and forces are some output data. For modelling reinforced concrete solid 65 element was used which consist of eight noded solid elements. These eight nodes are solid elements with three degrees of freedom at each of their nodes. It is also having three degrees of translation freedom in x, y, and the z direction. These type of elements can develop plastic hinges subjected to plastic deformation. For modelling reinforcing steel bars link180 element was used. These types of elements consist of two nodes, which are uniaxial tension compression elements. Each node has three degrees of translation freedom in the nodal x, y, and z directions. These types of elements are also capable of forming plastic hinges and plastic deformation. Hence, plastic deformation and nonlinearity can be simulated in this type of element.

VI. MODEL AND ANALYSIS

Geometrical model of confined and unconfined model were modelled in Ansys workbench 2021 R2. At first material properties, grade of concrete, grade of steels etc... Were defined. Unit was fixed in KN/N and mm/m. Reinforced concrete long column was modelled 300mmX400mmX7000mm (length X breadth X height). The longitudinal bar is 12 in number having the diameter 20mm. Transverse bars or lateral ties of 8mm diameter bars are provided at 300mm centre to centre along the unsupported length (height) of the long column. 50mm concrete cover is provided all around the confined long as well as conventional long column.

In element meshing column models were divided into small square or quadrilateral elements after all of the material and geometrical input data. Solid65 and link180 elements are linked and combine together or merge in Ansys resulting a single column model which is capable of simulating actual behaviour of conventional and confined long column. Average size of the mesh was fixed at 5mm. More the meshes are finer, greater the accuracy of the result obtained.

Once meshing was generated, next step is to assign boundary conditions Displacement boundary conditions are required to constrain the model and obtain a unique solution. To validate that the model behaves the same as the test columns boundary conditions must be applied to specimens when supports and loadings exist. The displacement of all nodes at the bottom base of the column in the y direction was set to zero ($U_y = 0$) which is fixed at bottom for both conventional and confined long column models. An axial pressure was applied over the entire top surface of the column model to simulate the axial load on the top of the long column specimens according to the displacement-loading protocol. The one end of the column was fixed and another end of column was subjected to gradually applied load.

After completion of all the steps which are mentioned above in both conventional and confined long column specimen, it would be undergoing non-linear analysis. After the analysis results are obtained in the form of total deformation, buckling load and ultimate load. The result of numerical analysis shows that deformation was maximum at the top face of the both conventional and confined long column.

A. Conventional Long Column

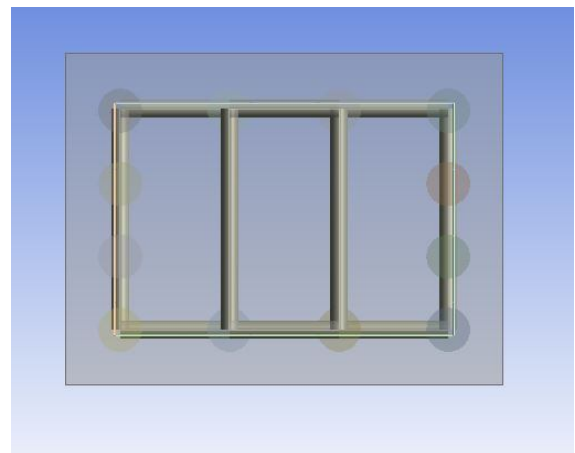
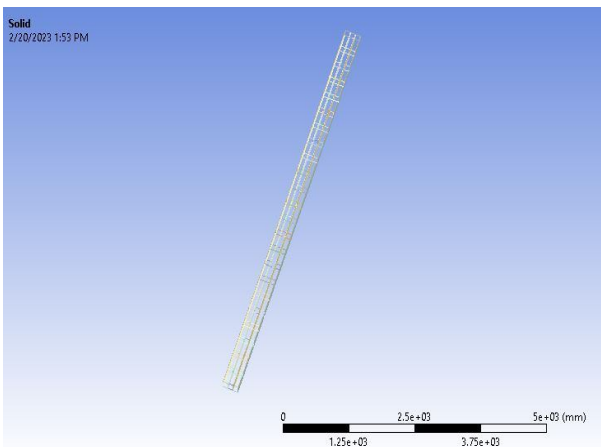

Figure 6.1. Side view and sectional view of conventional long column

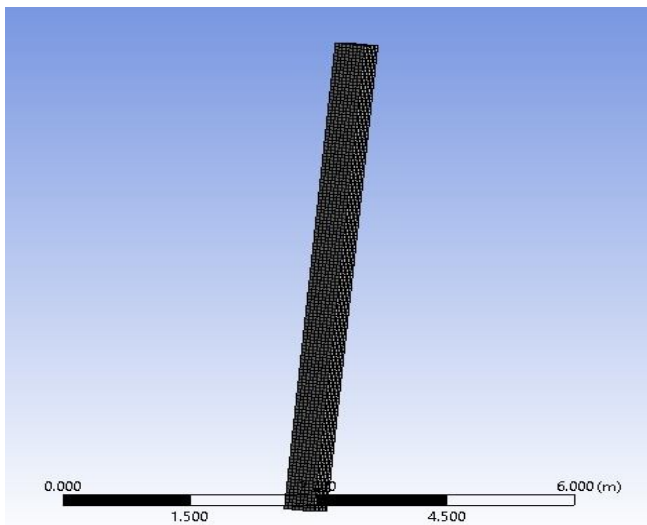

Figure 6.2. Meshing generated on the conventional long column

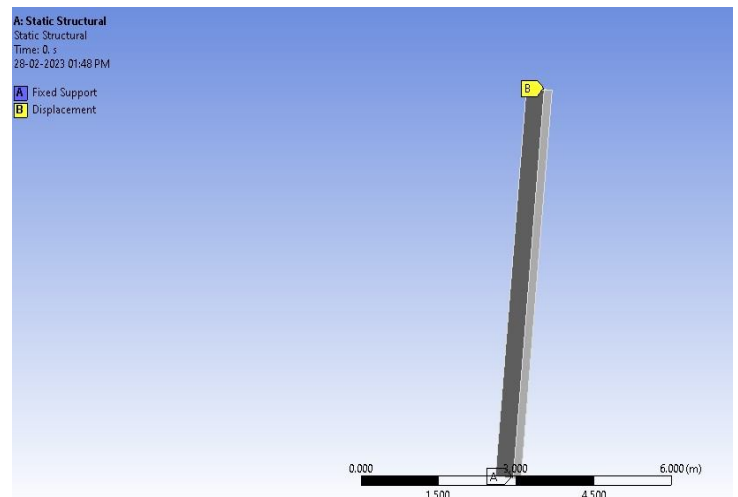

Figure 6.3 Applying BC to the conventional long column

B. Aluminium Confined Long Column

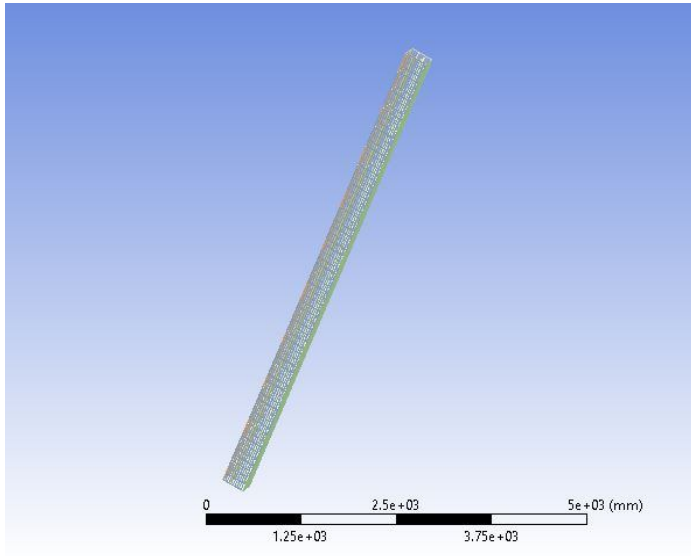

Figure 6.4 Side view of Al confined long column

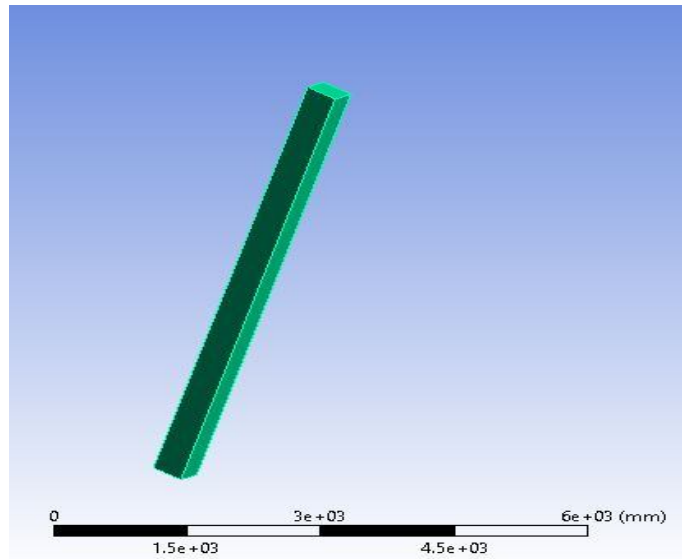

Figure 6.5 Al confined long column after defining concrete

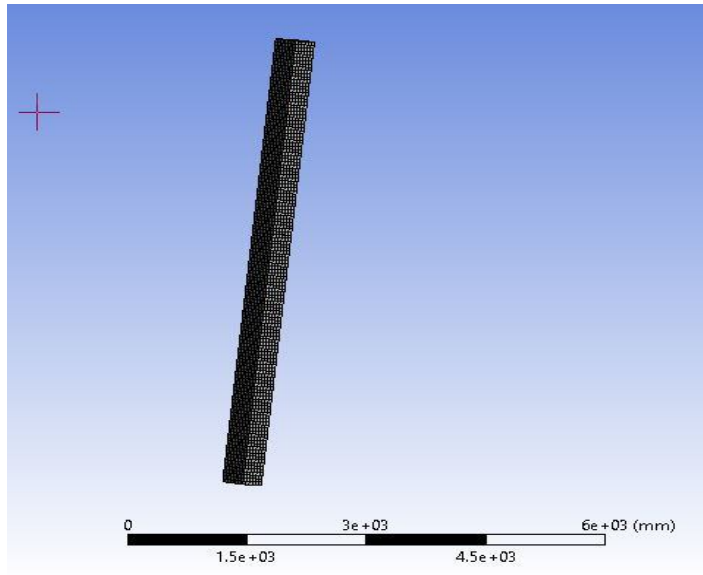

Figure 6.6. Mesh generated to Al confined long column

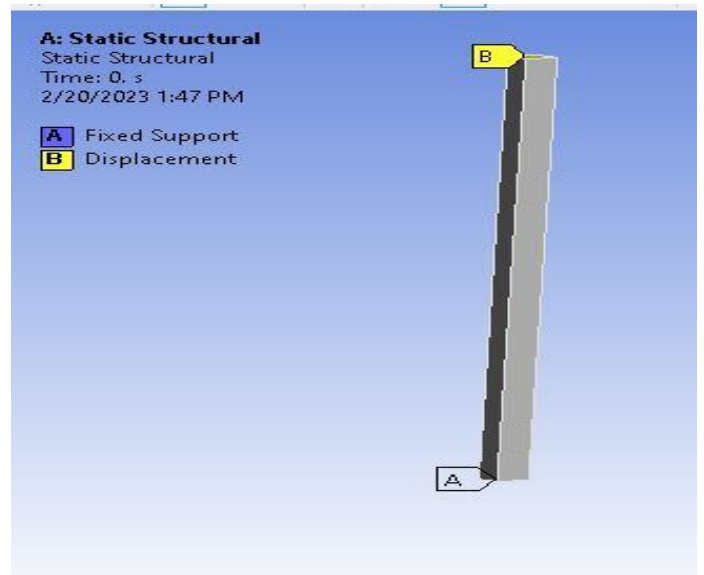

Figure 6.7. Applied BC to the Al confined long column

VII. RESULT AND EVALUATION

The results indicate that the actual behaviour of conventional long column and Aluminium mesh confining long column subjected to axial compressive load can be appropriately modelled in the Ansys workbench 2021 R2 and predicted its buckling load and ultimate load. It was revealed that the non-linear behaviour of confined long columns can be investigated using finite element models. The result of numerical analysis shows that deformation was maximum (maximum deformation value=25mm) at the top face of the both conventional and confined long columns. Detailed result evaluation are carried out here below. Values given in the red colour in the table represents the buckling load.

A. Conventional Long Column

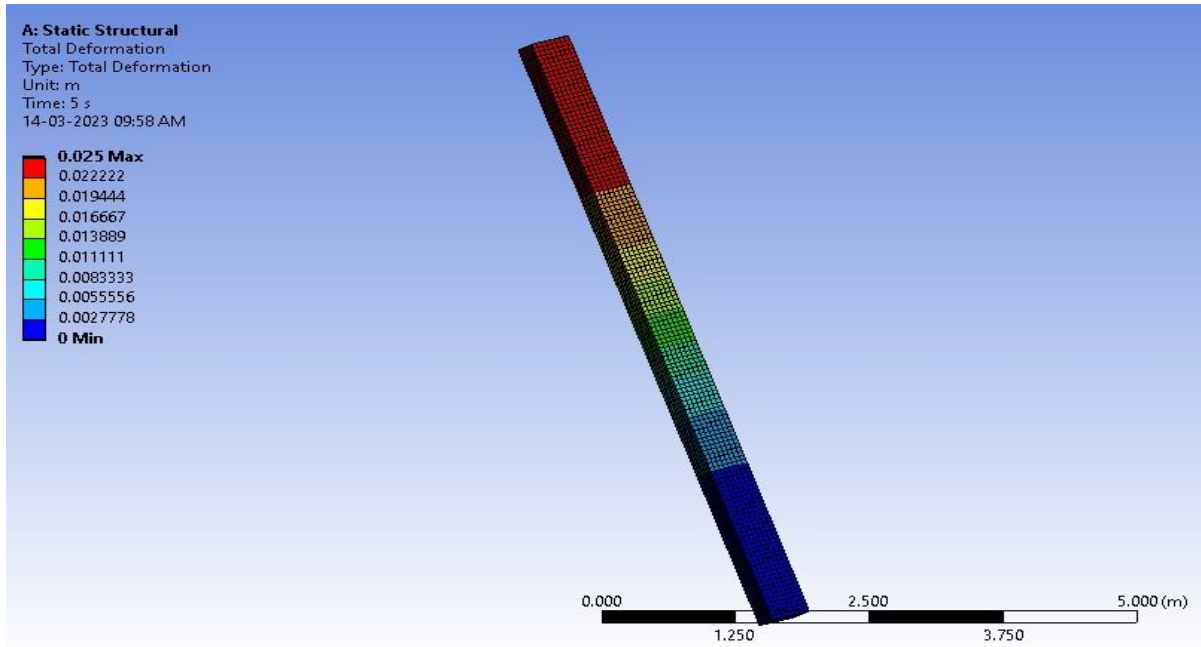

Figure 7.1. Total deformation on conventional long column

Table 7.1. Deformation V/S Load of Conventional long column

DEFORMATION (mm)	LOAD (KN)
0	0
5	4707.9
10	6146.1
13.375	6270.2
16.75	6339.9
21.812	6416.1
25	6511.1

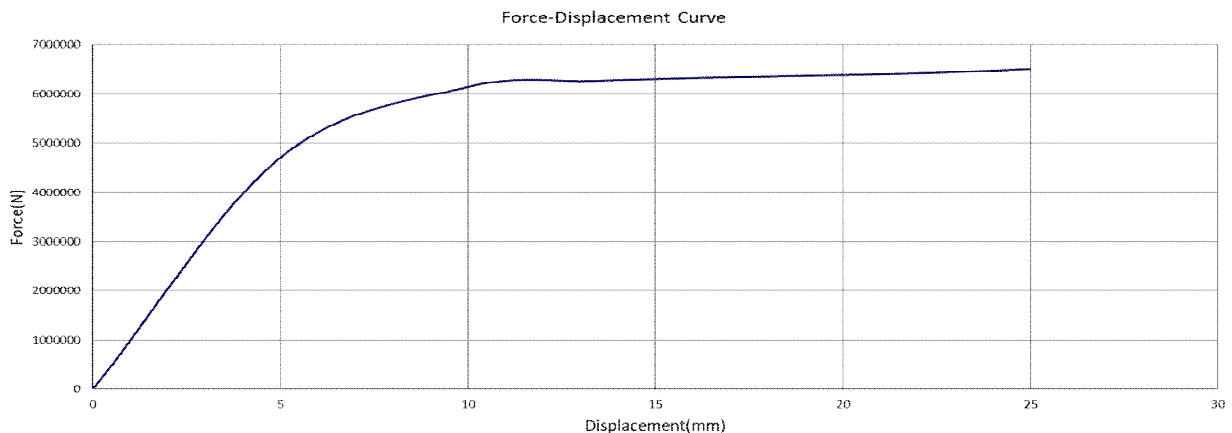

Figure 7.2. Curve of Deformation V/S Load of Conventional long column

B. Aluminium Confined Long Column

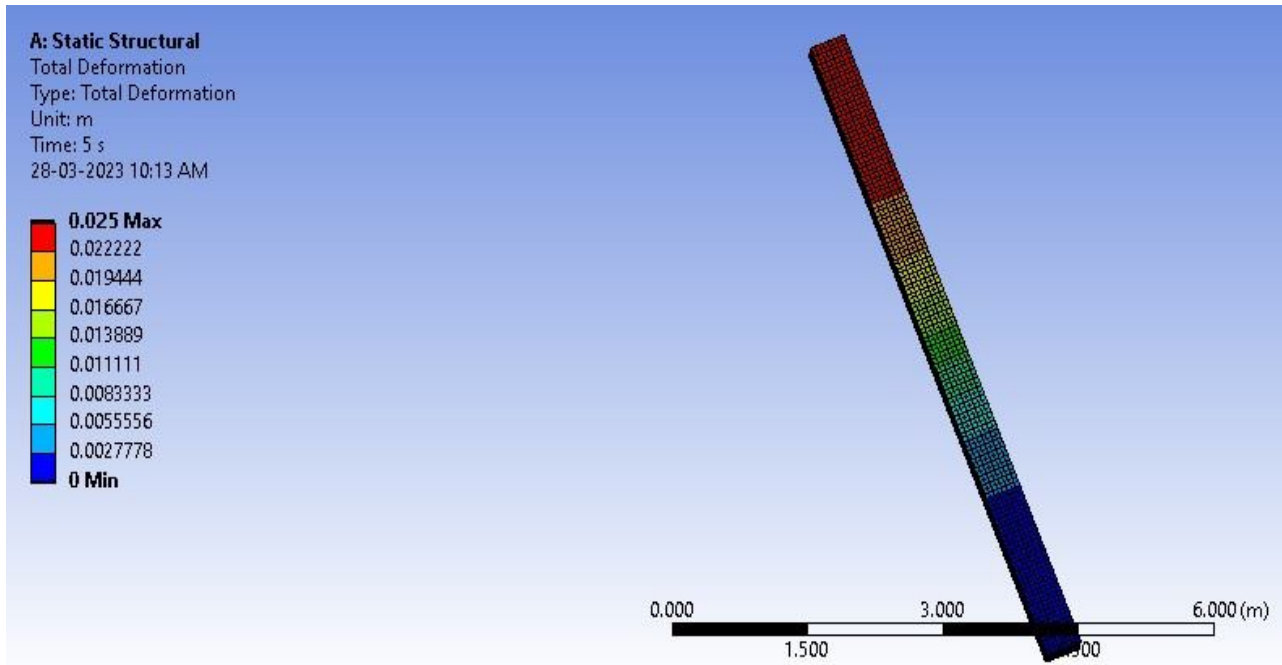

Figure 7.3. Total deformation on Al confined long column

Table 7.2 Deformation V/S Load of Al confined long column

DEFORMATION (mm)	LOAD (KN)
0	0
5	4889.2
10	6797.9
13.375	7102.8
16.75	7264.7
21.812	7444.6
25	7526.3

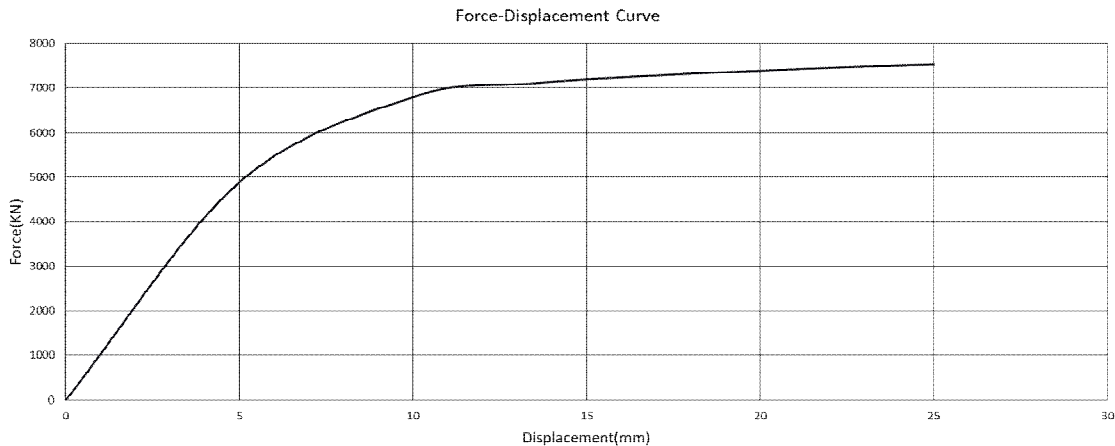

Figure 7.4. Curve of Force V/S Displacement of Al confined long column

C. Comparison Of Results And Discussion

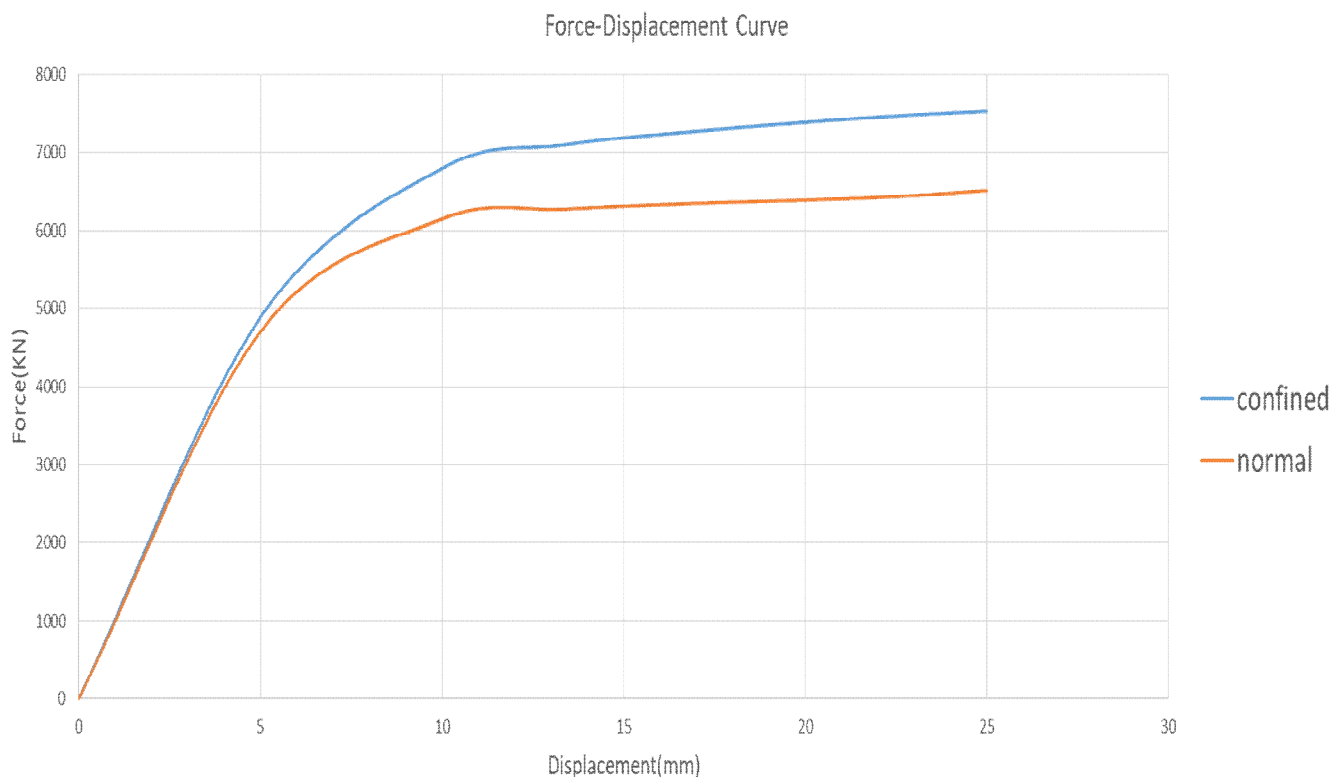

Figure 7.5. Comparison of curves obtained in conventional and Al confined long column

While comparing the results obtained from the nonlinear analysis of conventional long column and Al confined long column, the displacement or the maximum total deformation which the both conventional and confined long column can accommodate is 25mm. Beyond 25mm both long column unable to accommodate any further load acting on it and eventually undergo failure.

Both conventional and confined long column take load in elastic region comparably. After elastic region, from the transition region between the elastic and plastic region, the properties of both long column were differed from each other.

In conventional long column buckling starts at load more than 6270.2 KN corresponding to 13.375mm deformation. This is referred as buckling load. After this point, the load carrying capacity of the conventional long column substantially decreases. Then afterwards its ultimate load is taken as 6511.1 KN making maximum deformation 25mm.

In Al confined long column buckling starts at load more than 7102.8 KN corresponding to 13.375mm deformation and this load referred as buckling load acted on the Al confined long column. After elastic region, Al confined long column carried more amount of load than that of conventional long column. Ultimate load in the Aluminium confined long column is recorded as 7526.3 KN corresponding to maximum deformation 25mm which is considerably more than conventional long column.

VIII. CONCLUSION

From the results obtained after the nonlinear analysis in the Ansys workbench 2021 R2, it is observed that Aluminium confined long column is having much better behaviour and performance under axial loading than that of conventional long column. Here are some conclusions made below,

- 1) Buckling starts early in conventional long column as compared to Aluminium confined long column and buckling load is more in case of Aluminium confined long column than that of conventional column.
- 2) Load carrying capacity of conventional long column and Aluminium confined long column are comparable in elastic region.
- 3) Both conventional and confined long column undergo substantial decrease in load carrying after the transition region, but more reduction is seen in the case of conventional long column.

- 4) Load carrying capacity in the plastic region is higher in the Aluminium confined long column than that of conventional long column.
- 5) Aluminium confined long column carries higher load by making respective amount of deformation than that of conventional long column.
- 6) Over 14.1% increase in buckling load and 16.2% increase in ultimate load for Aluminium confined long column w.r.t conventional long column.
- 7) Overall behaviour and performance of Aluminium confined long column is much better than that of conventional long column.

IX. FUTURE SCOPE

In this confinement concept, there will be too much scopes are there in future because it is as such broader concept and lot more studies are yet to come by understanding the significance of confinement in columns. Amongst them here are some of future scope below,

- 1) This present work has taken the confinement material as Aluminium mesh because of its favourable properties for being taken as a confinement material. In future there may be a lot of options available for choosing a material as confinement material.
- 2) The present work has concentrated on the axially loaded columns only. In the future, work can be extended to columns subjected to lateral loads such as wind load and earthquake load, and also in uni-axial and bi-axial bending.
- 3) In the present work only M30 concrete and Fe415 steels are considered. Recent times there is a trend of using high grades of concrete and steel. In future effect of confinement in high grades of concrete and steel may be assessed.

REFERENCES

- [1] Khatri A.P., & Hinge G.A (2022) "Comparative study of confining reinforcement used for the rectangular concrete short column" Materials Today: Proceedings,(Elsevier), Science Direct, ISSN 0955-5986. Volume 49, Part 5, Pages 1844-1851.
- [2] Khatri A.P.,& Hinge G.A (2021) "Finite element analysis of confined rectangular short column". Design engineering Rogers Media Publishing Ltd. Pages 10708-10721, ISSN: 0011-9342, Volume 2021: Issue 07 Indexing: Scopus.
- [3] Khatri A.P.,& Hinge G.A (2021) " Study of diagonal ties and metal plates as a confining reinforcement for RCC short columns". Journal of Structural Engineering and Management ISSN 393-8773. Volume 08, Issue 3, Pages 39-46.
- [4] Ghanem, S. Y., & Elgazzar, H. (2021) "Predicting the behavior of reinforced concrete columns confined by fiber reinforced polymers using data mining techniques". SN Applied Sciences, 3(2), 1 13
- [5] Ali, M., Abbas, S., de Azevedo, A. R. G., Marvila, M. T., Alqurashi, M., Khan, M. I., Rafiq, W., & Hussein, E. E. (2021) "Experimental and analytical investigation on the confinement behavior of low strength concrete under axial compression". Structures, 36, 303 313.
- [6] Amir Khani S .,& Lezgy Nazargah M (2021) "Nonlinear finite element analysis of reinforced concrete columns". Evaluation of different modeling approaches for considering stirrupconfinement effects. Structural Concrete.
- [7] El-Kholy, A. M., & Dahish, H. A (2016) "Improved confinement of reinforced concrete columns". Ain Shams Engineering Journal, 7(2), 717 728.
- [8] Ibrahim, A. L., & Harba, S. I. (2012) "Non Linear Finite Element Analysis of Confined HSC Columns Under Concentric and Eccentric Loadings". Journal of Engineering and Development, 16(3), 1813 7822.
- [9] IS:2386- Part I. (1963). Method of test for aggregate for concrete. Part I - Particle size and shape. Indian Standards, (Reaffirmed 2002).
- [10] IS:383. (1970). Specification for Coarse and Fine Aggregates from Natural Sources for Concrete. Indian Standards, 124
- [11] Ozbakkaloglu T, Oehlers DJ. Concrete-filled square and rectangular FRP tubes under axial compression. J Compos Constr, ASCE 2008;12(4):469-77.
- [12] Dong CX, Kwan AKH, Ho JCM. A constitutive model for predicting the lateral strain of confined concrete. Eng Struct 2015;91:155-66.



10.22214/IJRASET



45.98



IMPACT FACTOR:
7.129



IMPACT FACTOR:
7.429



INTERNATIONAL JOURNAL FOR RESEARCH

IN APPLIED SCIENCE & ENGINEERING TECHNOLOGY

Call : 08813907089  (24*7 Support on Whatsapp)