



# IJRASET

International Journal For Research in  
Applied Science and Engineering Technology



---

# INTERNATIONAL JOURNAL FOR RESEARCH

IN APPLIED SCIENCE & ENGINEERING TECHNOLOGY

---

**Volume:** 10    **Issue:** VII    **Month of publication:** July 2022

**DOI:** <https://doi.org/10.22214/ijraset.2022.45350>

[www.ijraset.com](http://www.ijraset.com)

Call:  08813907089

E-mail ID: [ijraset@gmail.com](mailto:ijraset@gmail.com)

# Study on the Shear Capacity of Concrete Beam Reinforced with Glass Fiber Reinforced Polymers Grid Reinforcement

Burhana P<sup>1</sup>, Divya KK<sup>2</sup>

<sup>1</sup>Post graduate student (M.Tech Structural Engineering), APJ Abdul Kalam Technological University, Vedavyasa Institute of Technology, Kerala, India

<sup>2</sup>Associate Professor, Vedavyasa Institute of Technology, Kerala, India

**Abstract:** Fiber Reinforced Polymer (FRP) composites have been widely used as a high-performance material in concrete structures as replacement of commonly using materials. Corrosion of the internal reinforcing steel is the main cause of deterioration in reinforced concrete structures. This steel in reinforced concrete structures has cost a significant amount of resources globally over the past, also expensive as compared to FRP. Glass fiber reinforced polymer (GFRP) bars have been introduced as a light-weight, corrosion resistant FRP material which can be used as replacement for traditional steel reinforcing bars and stirrups in concrete structures. Glass fiber reinforcement polymer (GFRP) bars are also feasible and cost effective FRP products commercially available with significant cost advantage over stainless steel. The aim of this paper is to let engineers gain a better knowledge of the overall behaviour of GFRP as internal reinforcement so that they have more confidence using it as a sustainable material. In this study GFRP is used as longitudinal reinforcement and GFRP grid is used as stirrups. A Finite Element (FEM) model has been developed using ANSYS 21 to analyse beams. For these six concrete beams, including one steel reinforced concrete (RC) beam and five beams with GFRP grids laid parallel to longitudinal axis was tested until failure. Parametric study on shear span ratio is conducted in four specimens. Load deflection curve are noted in each specimen analytically by using ANSYS software.

**Keywords:** Glass Fiber Reinforced Polymer (GFRP), Parametric study, Ultimate Load, load deflection curve

## I. INTRODUCTION

FRP reinforcements have a number of advantages such as corrosion resistance, non-magnetic properties, high tensile strength, lightweight and can be handle easily. They also have poor resistance to fire and when they are exposed to high temperatures. Corrosion of reinforcing steel is a major problem for concrete structures. Glass fiber reinforced polymers are high value-added construction product having a potential to extend the life of public structures. Glass fiber have high cementitious properties, so they can be used as an alternative to cement in concrete.

Cement production produces large amount carbon dioxide gas, that is not good for the environment, so replacing cement with these glass fibers can reduce amount of carbon dioxide. Glass industries also facing a problem related to glass waste which are hazardous. Traditional steel bars used in RCC structures are slowly being replaced with glass fiber reinforced polymer (GFRP) bar. This change in construction industry can improve high strength, corrosion resistance, durability and cost effective as compared to conventional steel rods.

The objective of this study is comparing the shear behaviour of concrete beam reinforced with GFRP grid shear reinforcement and RC beam with steel stirrup. The experiment variable includes shear span ratio, ultimate load and maximum deflection and shear reinforcement ratio. Six beams are casted, four of them with GFRP stirrups placed perpendicular to longitudinal axis.

And one control beam with steel stirrups perpendicular to longitudinal axis.

Parameter shear span ratio is conducted by changing shear span in four beams. In one beam shear reinforcement ratio analysed by changing spacing of stirrups. Shear span ratio changes from 0.5 to 1. From the result obtained it can conclude that when shear span ratio changes from 0.5 To 1, the ultimate capacity of beam decreases. Maximum load obtained when shear span ratio is 0.5, also when shear reinforcement ratio changes, the ultimate load decreases. So we conclude that when GFRP grid used as stirrup, it can increase the ultimate load carrying capacity of beam.

## II. OBJECTIVE OF PRESENT STUDY

- 1) Compare numerical analysis of shear strength characteristics of GFRP grid shear reinforced concrete beam reinforced with steel stirrup typically used as shear reinforcement.
- 2) The second objective is to perform parametric analysis on shear span ratio of GFRP reinforcement.
- 3) To study the effect of shear reinforcement ratio.

## III. STAGES INVOLVED IN FINITE ELEMENT MODELLING

### A. Design of Beam

All beams are designed according to ACI 440.1R-15, guide for design and structural concrete reinforced with Fiber-reinforced with Fiber-Reinforced Polymer (FRP) Bars reported by ACI committee 440. Width of 150 mm, depth of 300 mm and length of 750 mm is adopted. Effective span of 670 mm. All beams were tested under four-point bending condition. Total six beams are modelled and analyzed numerically by software ANSYS 2021 R2. According to stirrup material, the six beams could be classified into two types: in Type 1, the 70 × 70 mm CFRP grids were arranged perpendicular to the longitudinal axis of the beam as stirrups. Type 3 was the control group with steel stirrups of spacing 140 mm. Details of type 1 beam shown in Fig 1, and Type 2 shown in Fig 2. Another experimental variable was shear reinforcement ratio which was controlled by changing the spacing of stirrups in Type 1. Shear span ratio 0.5, 0.67, 0.83 and 1 are modeled and analyzed in Type 1 beam. Control beam were modeled for shear span ratio 0.67. Also for shear reinforcement ratio, the beam modeled at a shear span ratio 0.67. Comparison of these beams with the control beam shows the result. Load deflection curve is considered the key aspect in studying the beams behavior. The beam types were identified as B1-0.5-140. The first term of the identification corresponded to a beams group. The second parameter identifies the shear span ratio. The last term indicates the spacing of GFRP vertical stirrups and steel stirrup

Details of beam

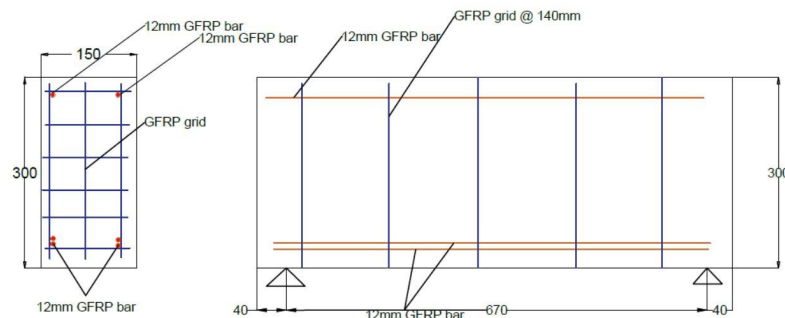

Fig: 1 Model of Type 1 beam

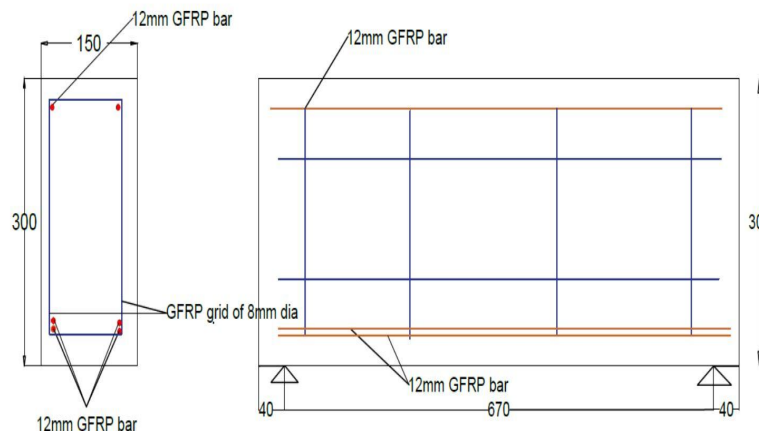

Fig: 2 Model of Type 2 beam

TABLE 1: REINFORCEMENT DETAIL OF TEST SPECIMENS

Specimens	Width (mm)	Height (mm)	Shear reinforcement ratio	Shear reinforcement	Shear span ratio
B1- 0.5- 125	150	300	0.52	Type 1 @ 140mm	0.5
B1- 0.67 - 125	150	300	0.52	Type 1 @ 140mm	0.67
B1- 0.83 - 125	150	300	0.52	Type 1@ 140mm	0.83
B1 – 1 - 125	150	300	0.52	Type 1@ 140mm	1
B1 – 0.67 - 175	150	300	0.34	Type 1@ 175mm	0.67
B2- 0.67 - 125	150	300	0.43	Type 3 @ 140mm	0.67

**B. Properties of Material**

Concrete mix M20 were adopted. All the main reinforcements are GFRP rebars. Grid of size 70mm×70mm and diameter 8 mm were used as stirrup in Type 1, and steel stirrup of grade Fe 500 and diameter 8mm were used for modelling. Property of concrete shown in Table II. Properties of GFRP rebar shown in Table III.

TABLE II: PROPERTIES OF CONCRETE

Youngs modulus	Shear modulus	Bulk modulus	Poisson's ratio	Density(Kg/m <sup>3</sup> )	Compressive strength
22360 MPa	9583.3 MPa	12778 MPa	0.2	2400	22.6

TABLE III. PROPERTIES OF GFRP REBAR

Diameter of bar	Youngs modulus	Poissons ratio	Density (Kg/m <sup>3</sup> )	Ultimate tensile strength (MPa)	Shear modulus (MPa)	Bulk modulus (MPa)
12 mm	46400 MPa	0.3	2100	752	38667	17846

### C. Modelling of Beams

The models are created using the ANSYS 2021 R1 software. Type 1 beams are modelled for four shear span ratios 0.5, 0.67, 0.83 and 1. Also one with shear reinforcement ratio 0.34, and control beam with steel stirrup at spacing 140mm.

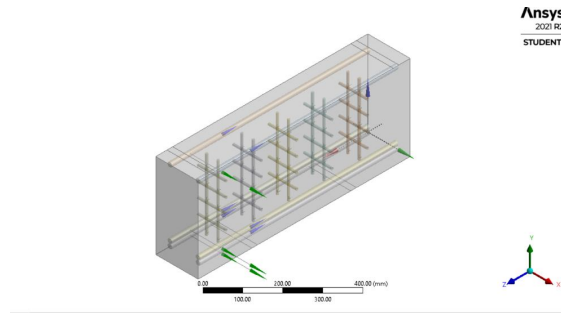

Fig: 3 Model of Type 1 beam

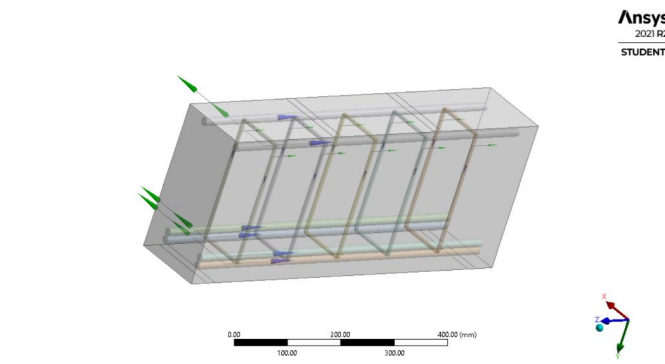

Fig: 4 Model of control beam

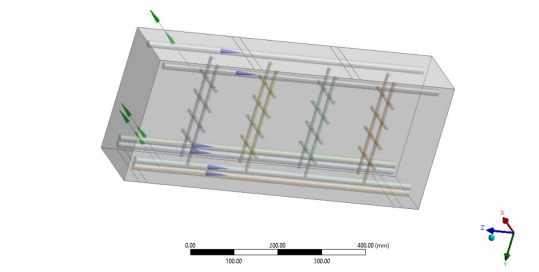

Fig: 5 Model of beam B1-0.67-175

### D. Meshing

Meshing is done to reduce the time taken to analyse the model and to get accurate results. A mesh size of 10mm is given to all beams.

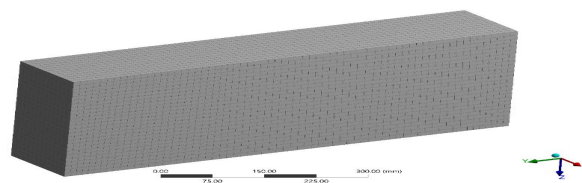

Fig: 6 Finite element meshing of beam



**E. Setup**

For this load and boundary conditions are applied to the beam modelled in ANSYS software. Hinge support is provided at a distance 40 mm from both ends. And load is provided according to shear span ratio. All the beams subjected to four point bending by applying four point loads at the top which are equidistant from the center line of the beam. The position of the point loads was chosen such that a shear span ratio ranges from 0.5 to 1. The effective span was kept at 670 mm for which a shear span of 150mm, 200 mm, 250 mm and 300 mm was considered for the study of shear behavior of the Type 1 GFRP grid shear reinforced beams. Shear span of 200 is considered for B1-0.67-175 and B2-0.67-140.

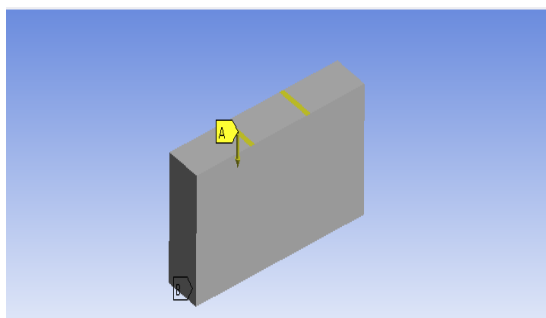

Fig: 7 Boundary condition of B1-0.5-140

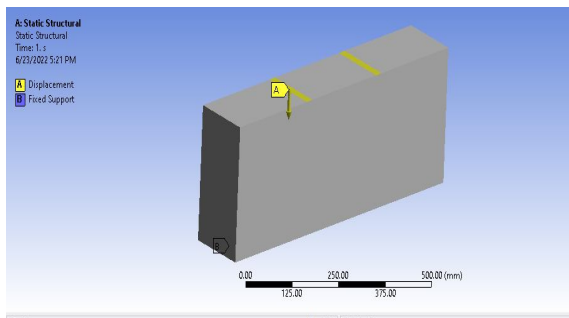

Fig: 8 Boundary condition of B1-0.67-140

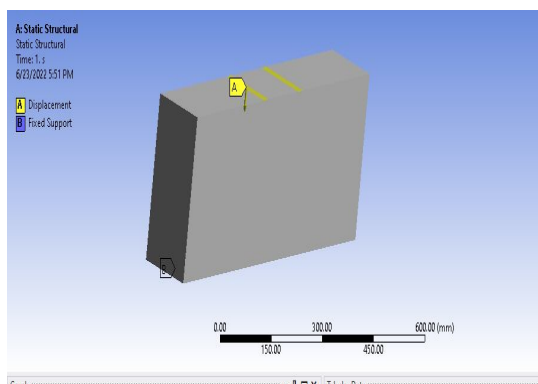

Fig: 9 Boundary condition of B1-0.83-140

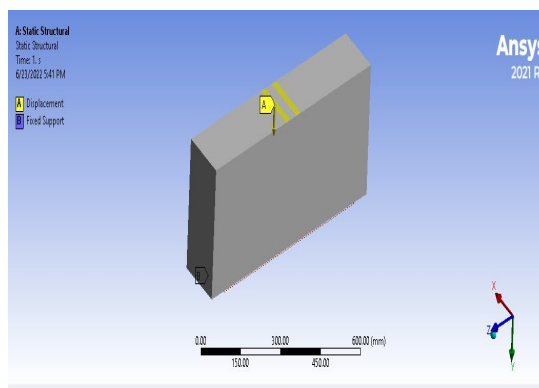

Fig: 10 Boundary condition of B1-1-140

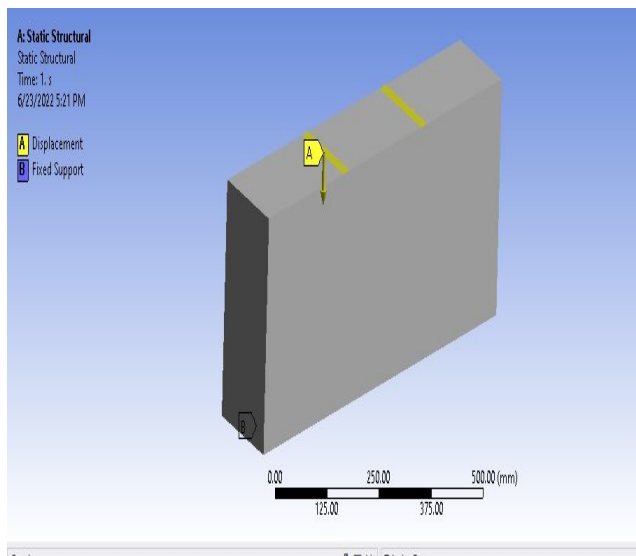

Fig: 11 Boundary condition of B1-0.67-175 and B2-0.67-140

**F. Solution**

The result obtained are total deformation diagram and equivalent stress diagram. From the result obtained load deformation graph is plotted in excel sheet. From the graph, we can understand the ultimate load carrying capacity of each beam. The load deflection curve of beams was compared with control beam and the result was obtained.

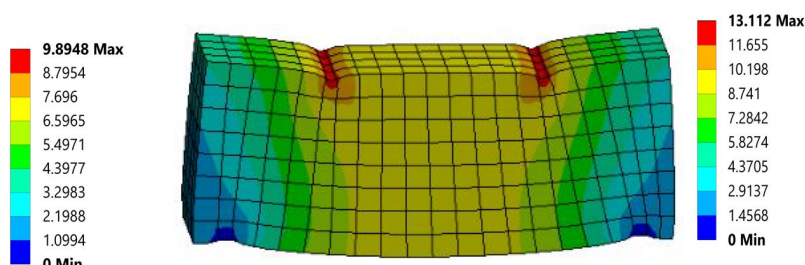

Fig:12a. Deformation diagram of B1-0.5-140

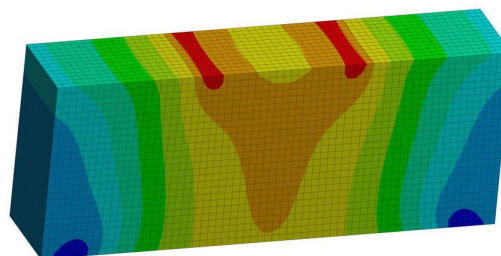

Fig:12b. Deformation diagram of B1-0.67-140

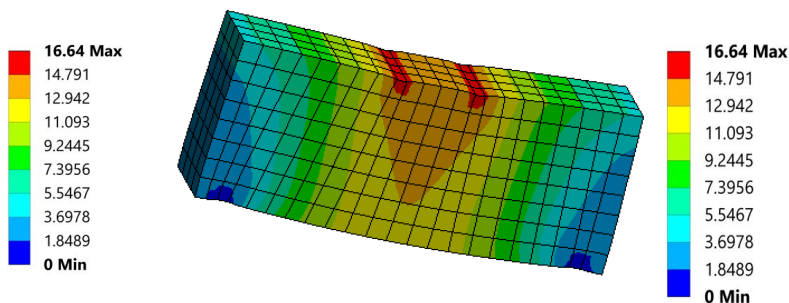

Fig:12c. Deformation diagram of B1-0.83-140

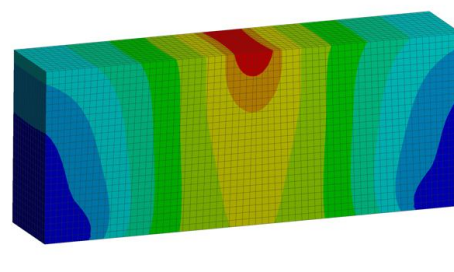

Fig:12d. Fig:8a. deformation diagram of B1-1-140

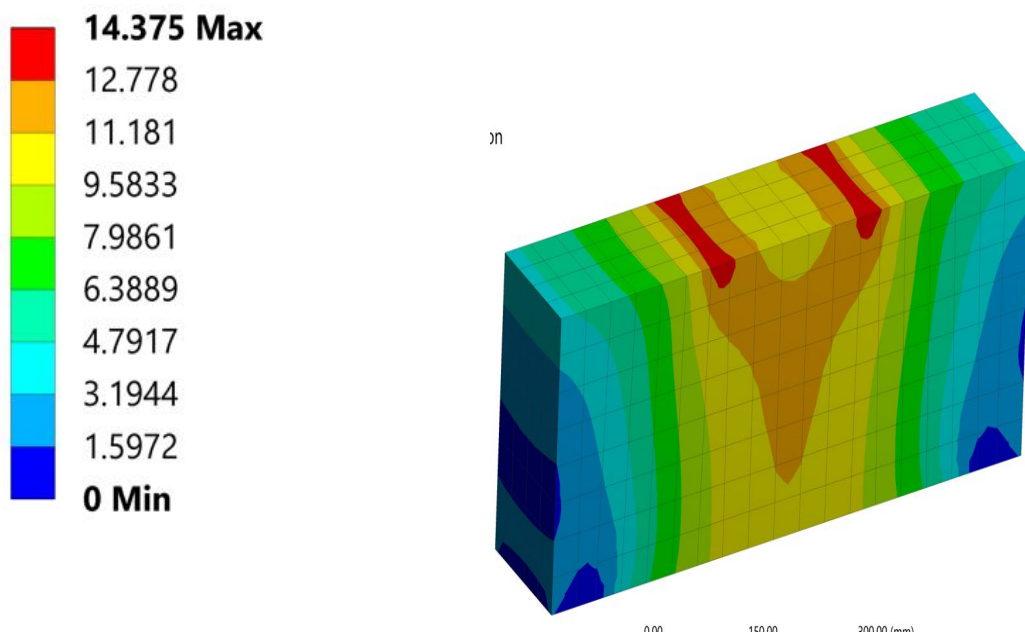

Fig:12e. Deformation diagram of B1-0.67-175

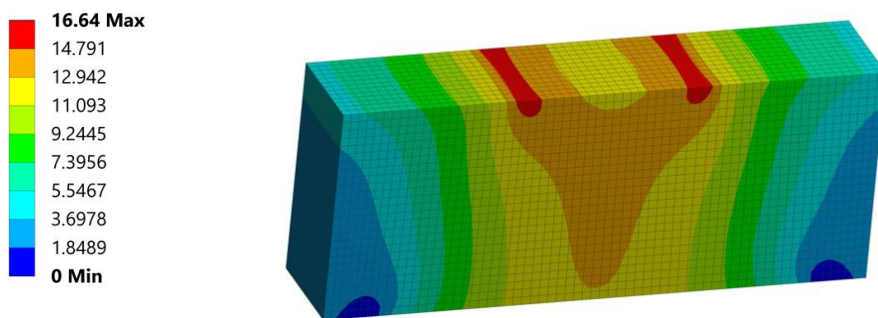

Fig:12f. Deformation diagram of Type 2  
Fig:12. Deformation diagrams

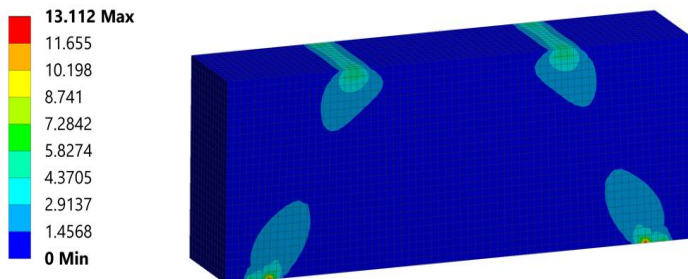

Fig:13a. Equivalent stress diagram of B1-0.5-140

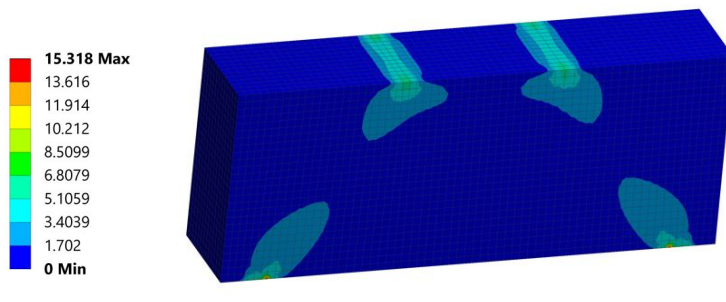

Fig:13b. Equivalent stress diagram of B1-0.67-140

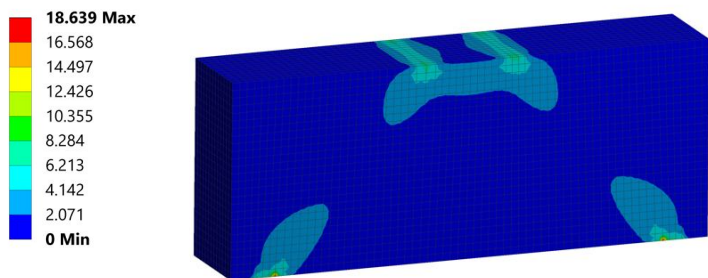

Fig:13c. Equivalent stress diagram of B1-0.83-140

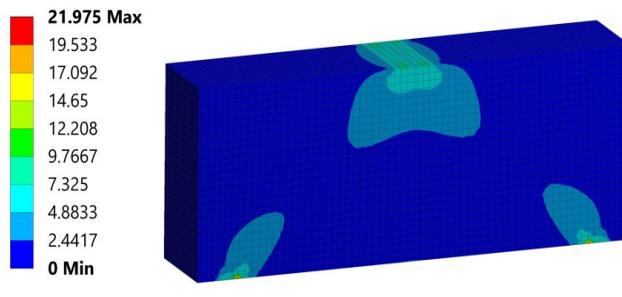

Fig:13d. Equivalent stress diagram of B1-1-140

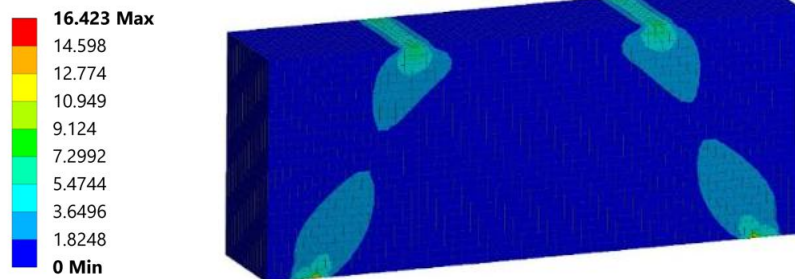

Fig:13e Equivalent stress diagram of B1-0.67-175

ormation diagram of Type 3



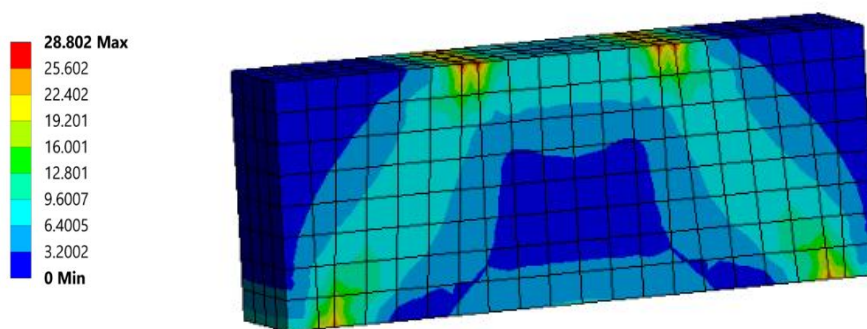

Fig:13f. Equivalent strain diagram of Type 2  
 Fig:13. Equivalent stress diagram of all beams

#### IV. RESULTS AND DISCUSSION

From the result obtained we can understand that beam with GFRP grid as shear reinforcement have highest load carrying capacity as compared to control. When shear span ratio increases the load carrying capacity decreases. The load versus deformation graph is shown below. From the load deformation curve, when shear reinforcement ratio decreases ultimate load capacity of beam also decreases. Maximum load carrying capacity of beam is obtained when shear span ratio is 0.5. Percentage increase of 64.1% when shear span ratio is 0.5. When shear reinforcement ratio decreases ultimate load decreases to 18.83%.

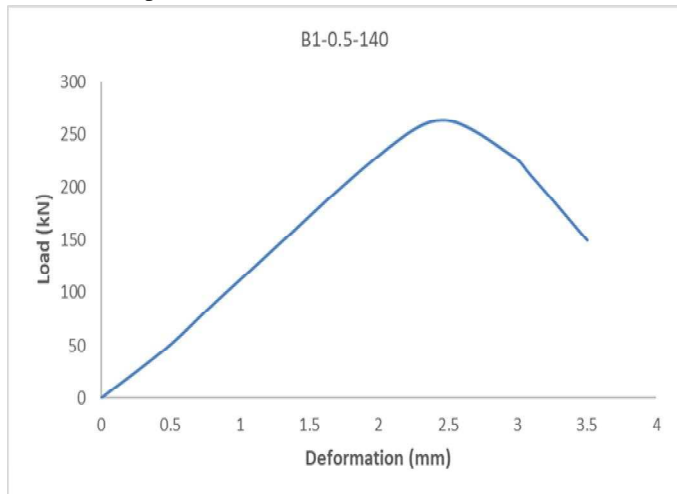

Fig:9. Load deflection deformation curve of B1-0.5-140

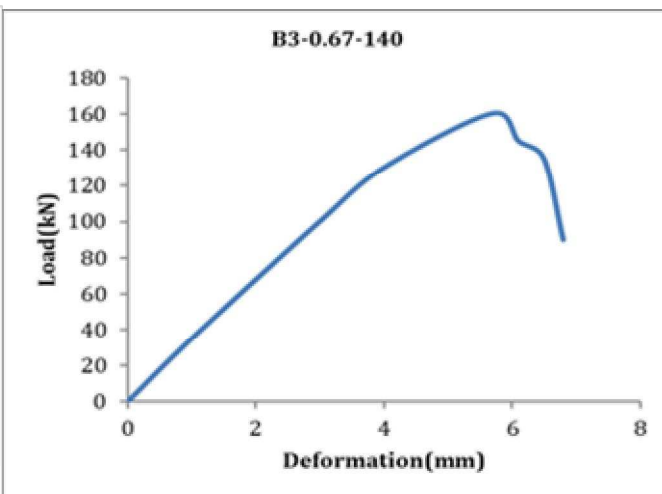

Fig:10. Load deformation curve of B1-0.67-140

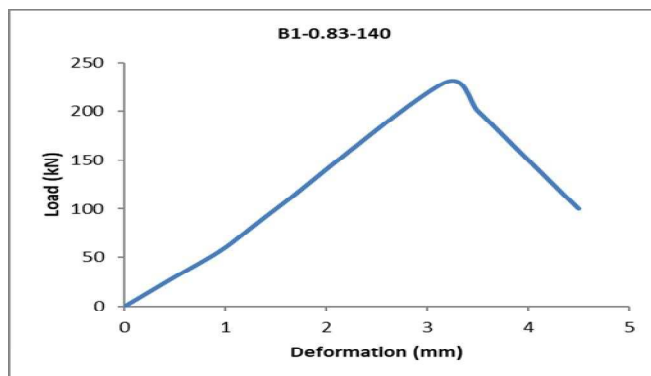

Fig:9. Load deflection deformation curve of B1-0.83-140

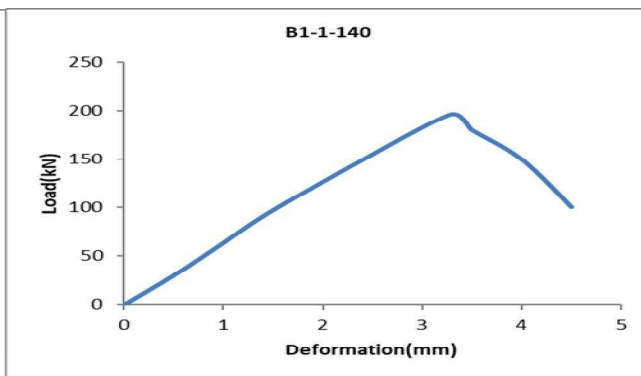

Fig:10. Load deformation curve of B1-1-140

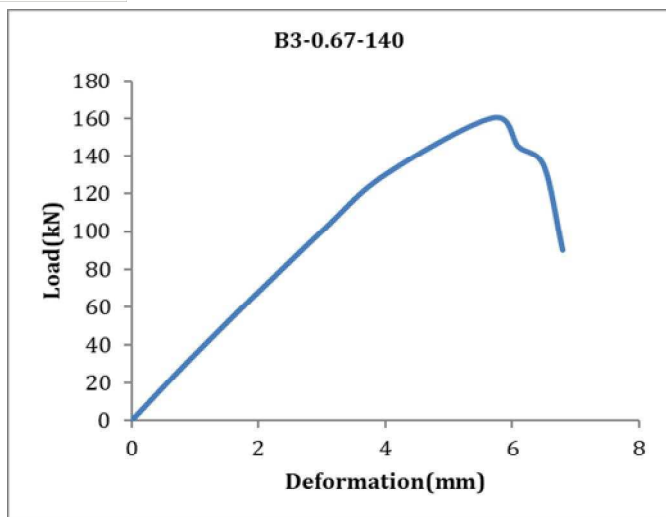

Fig:11. Load deformation curve of B3-0.67-140

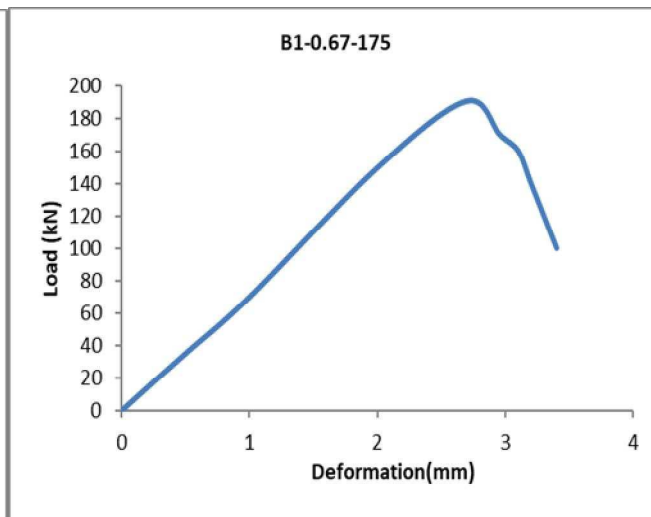

Fig:12. Load deformation curve of B1-0.67-175

TABLE IV  
COMPARISON OF MAXIMUM LOAD WHEN SHEAR SPAN RATIO CHANGES FROM 0.5 TO 1

Specimen	Load (kN)	Deformation(mm )	Percentage increase
B1-0.5-140	263 kN	2.46	64.1%
B1-0.67-140	246.9 kN	2.84	54.06%
B1-0.83-140	228.93 kN	3.17	42.84%
B1-1-140	195.46 kN	3.26	21.96
Control beam	160.26 kN	5.701	

TABLE V  
COMPARISON OF MAXIMUM LOAD WHEN SHEAR REINFORCEMENT RATIO CHANGES

Specimen	Load (kN)	Deformation(m m)	Percent age increase
B1-0.67-140	246.9 kN	2.84	54.06%
B1-0.67-175	190.44 kN	2.693	18.83%
Control beam	160.26 kN	5.701	

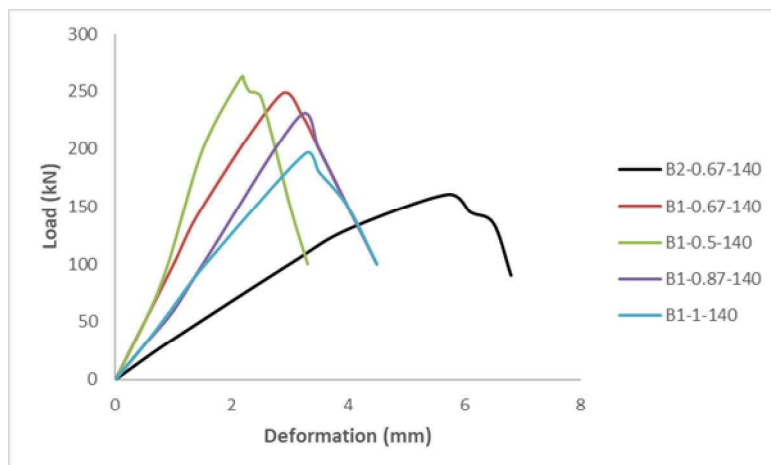

Fig.13. Comparison of Load deformation of shear span ratio ranges 0.5 to 1 with control beam

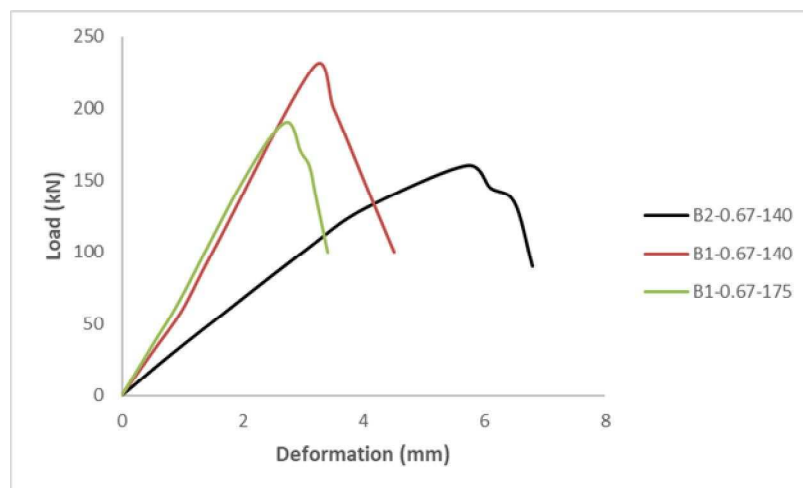

Fig.9. Load deflection deformation curve of when shear reinforcement ratio changes with control beam

## V. CONCLUSIONS

This work deals with analysis of beam ANSYS software. The parameters include shear span ratio and shear reinforcement ratio.

- 1) From the analysis it can conclude that when shear span ratio increases, ultimate load decreases.
- 2) When shear reinforcement ratio changes the ultimate load decreases.
- 3) In general, we can understand GFRP grid can used effectively as stirrup in concrete beams. It can reduce so many environmental problems and corrosion problems.

## REFERENCES

- [1] Zhen Huang, Xio Miao, Experimental investigation on shear behaviour of concrete beams with CFRP grid shear reinforcements, journal of structures 33(2021) 3081-3093.
- [2] Tarek h. Almusallam and yousef a. Al-salloum Durability of gfrp rebars in concrete beams under sustained loads at severe environments, Journal of composite materials, vol. 40, no.7, 2006.
- [3] H. Akbarzadeh, A.A. Maghsoudi, Experimental and analytical investigation of reinforced high strength concrete continuous beams strengthened with fiber reinforced polymer, Materials and Design 31 1130–1147, 2010.
- [4] Andi Arwin Amiruddina, Shear Behavior of Concrete Beams Strengthened with CFRP Grid and PCM Shotcrete, EPI International Journal of Engineering Volume 2, Number 1, February 2019, pp. 5-8
- [5] Axetha Menam, K. Sunil Kumar, P. Rupa, Flexural and Shear Behavior of Beams Reinforced with GFRP Rebars, International Journal of Recent Technology and Engineering (IJRTE) ISSN: 2277-3878, Volume-9 Issue-5, January 2021.
- [6] Md. Akter Hosen, U.Johnson Alengaram, Mohd Zamin Jumaat , N. H. Ramli Sulong and Kh. Mahfuz ud Darain, Glass Fiber Reinforced Polymer (GFRP) Bars for Enhancing the Flexural Performance of RC Beams Using Side-NSM Technique, International Journal of Engineering Volume 2, pp. 4-8.



- [7] J.Y lee a, T.Y kim a, T.J kim a, J.A.O. Barros , S.J.E. Dias, J.L.T. Lima Efficacy of CFRP-based techniques for the flexural and shear strengthening of concrete beams, *Cement & Concrete composites* 29 203–217, 2007.
- [8] C.K yi b, J.S park c, Y.C you c, Y.H park Interfacial bond strength of glass fiber reinforced polymer bars in high-strength, *Concrete composites: part b* 39 258–270, 2008.
- [9] G. Sakar a, R.A. Hawileh b, M.Z. Naser b, J.A. Abdalla b, M. Tanarslan, Nonlinear behavior of shear deficient RC beams strengthened with near surface mounted glass fiber reinforcement under cyclic loading, *Materials and Design* 61 16–25, 2014.
- [10] Ali S. Shanour, Behavior of Concrete Beams Reinforced with GFRP Bars, Ph.D. Dissertation, Faculty of Engineering, Shoubra, Benha University, Cairo, Egypt, 2014



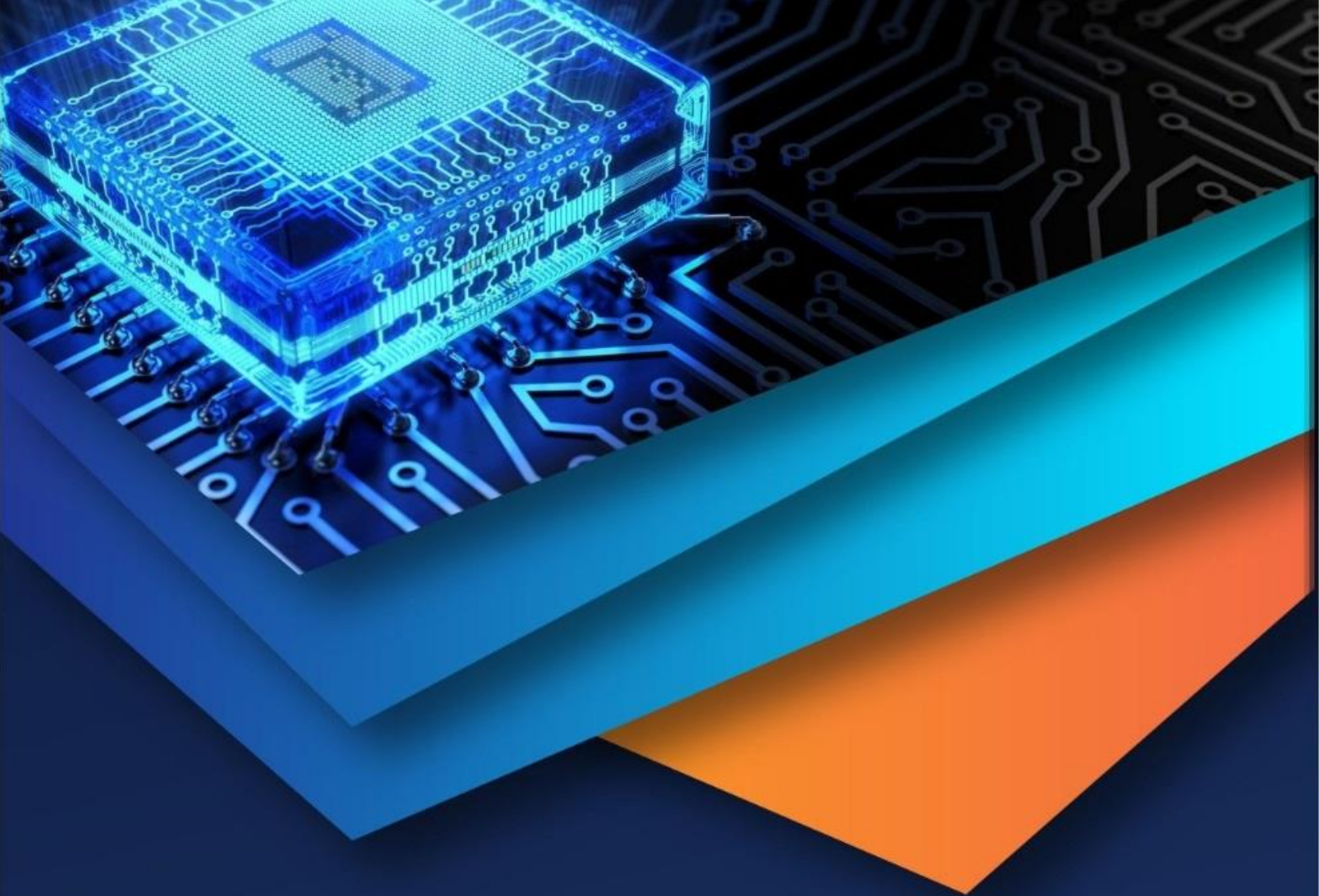

10.22214/IJRASET



45.98



IMPACT FACTOR:  
7.129



IMPACT FACTOR:  
7.429



# INTERNATIONAL JOURNAL FOR RESEARCH

IN APPLIED SCIENCE & ENGINEERING TECHNOLOGY

Call : 08813907089  (24\*7 Support on Whatsapp)